

Ventose

- Due tipologie: piane o con 1.5 soffietti.
- Tre materiali: Silicone, EPDM, gomma naturale.
- Diametri da 11mm a 53mm.

Vacuum cups

- Two styles: flat or with 1.5 bellows.
- Three materials: Silicone, EPDM, natural rubber.
- Diameters from 11mm to 53mm.

Ventose piane / Flat vacuum cups

Codice / Code

V 0 1



Ventose a soffietto / Bellow vacuum cups

Codice / Code

V 0 2



Scelta del materiale

Le ultime tre cifre del codice identificano il materiale ed il colore.

Material choice

The three final characters in the code identify the material and the color.

Codice / Code

S 0 1

Silicone
Silicone



Codice / Code

E 0 2

EPDM
EPDM



Codice / Code

R 0 3

Gomma naturale
Natural rubber



Colore Color	Rosso Red	Nero Black	Verde Green
Durezza (Sh.A) Hardness	55	48	53
Temperatura di esercizio Temperature range	-70° ÷ +200°C.	-40° ÷ +100°C.	-40° ÷ +80°C.
Applicazioni tipiche Typical applications	Alimentare Food	Automobile Automotive	Carta Paper

Dimensioni

Dimensions

V01	P/G	D1 [mm]	D3 [mm]	H1 [mm]	R [mm]	s [mm]	V [cm ³]	m [g]	F [N]
V0111S01	P	Ø11	Ø10	10	8	0.5	0.2	0.6	4
V0111E02	P	Ø11	Ø10	10	8	0.5	0.2	0.6	4
V0111R03	P	Ø11	Ø10	10	8	0.5	0.2	0.6	4
V0116S01	P	Ø16.2	Ø10	10.5	8	1.5	0.3	0.6	8
V0116E02	P	Ø16.2	Ø10	10.5	8	1.5	0.3	0.6	8
V0116R03	P	Ø16.2	Ø10	10.5	8	1.5	0.3	0.6	8
V0122S01	G	Ø22	Ø15	11.5	13	2.5	1.1	1.3	12
V0122E02	G	Ø22	Ø15	11.5	13	2.5	1.1	1.2	12
V0122R03	G	Ø22	Ø15	11.5	13	2.5	1.1	1.2	12
V0133S01	G	Ø32	Ø19	12.5	20	3.5	1.7	2.7	25
V0133E02	G	Ø32	Ø19	12.5	20	3.5	1.7	2.6	25
V0133R03	G	Ø32	Ø19	12.5	20	3.5	1.7	2.7	25
V0142S01	G	Ø41	Ø19	15.5	30	4.5	3.5	4.8	40
V0142E02	G	Ø41	Ø19	15.5	30	4.5	3.5	4.6	40
V0142R03	G	Ø41	Ø19	15.5	30	4.5	3.5	4.7	40
V0153S01	G	Ø51.4	Ø19	20	35	6	8	8.9	64
V0153E02	G	Ø51.4	Ø19	20	35	6	8	8.4	64
V0153R03	G	Ø51.4	Ø19	20	35	6	8	8.6	64

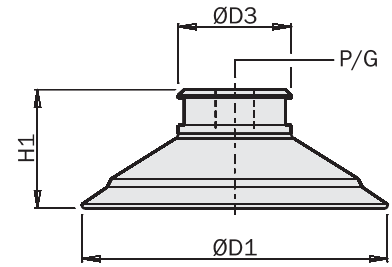

V02	P/G	D2 [mm]	D4 [mm]	D5 [mm]	H2 [mm]	R [mm]	s [mm]	V [cm ³]	m [g]	F [N]
V0211S01	P	Ø11	Ø10	Ø12	15.4	4	4.5	0.4	0.8	3
V0211E02	P	Ø11	Ø10	Ø12	15.4	4	4.5	0.4	0.8	3
V0211R03	P	Ø11	Ø10	Ø12	15.4	4	4.5	0.4	0.8	3
V0216S01	P	Ø15.7	Ø10	Ø17.5	18.8	5	6.5	1	1.3	6
V0216E02	P	Ø15.7	Ø10	Ø17.5	18.8	5	6.5	1	1.2	6
V0216R03	P	Ø15.7	Ø10	Ø17.5	18.8	5	6.5	1	1.2	6
V0222S01	P	Ø22	Ø10	Ø23	19	10	10	2	1.7	11
V0222E02	P	Ø22	Ø10	Ø23	19	10	10	2	1.6	11
V0222R03	P	Ø22	Ø10	Ø23	19	10	10	2	1.6	11
V0233S01	G	Ø34	Ø19	Ø36	26	15	15	10	5.3	27
V0233E02	G	Ø34	Ø19	Ø36	26	15	15	10	5	27
V0233R03	G	Ø34	Ø19	Ø36	26	15	15	10	5.1	27
V0242S01	G	Ø42	Ø19	Ø45	28	20	15	14	8.6	39
V0242E02	G	Ø42	Ø19	Ø45	28	20	15	14	8.2	39
V0242R03	G	Ø42	Ø19	Ø45	28	20	15	14	8.4	39
V0253S01	G	Ø53	Ø19	Ø57	35	30	15	30	14.8	64
V0253E02	G	Ø53	Ø19	Ø57	35	30	15	30	14	64
V0253R03	G	Ø53	Ø19	Ø57	35	30	15	30	14.4	64

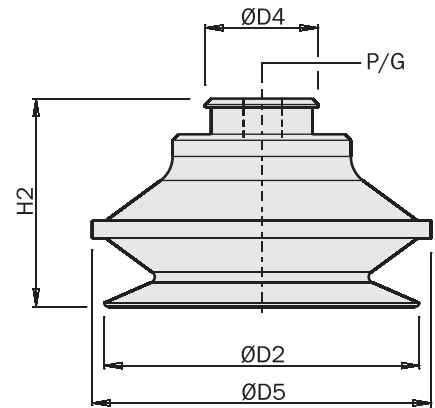

P/G In base al diametro esistono due tipi di attacco: tipo P e tipo G
According to the cup diameter there are two connections: P type and G type

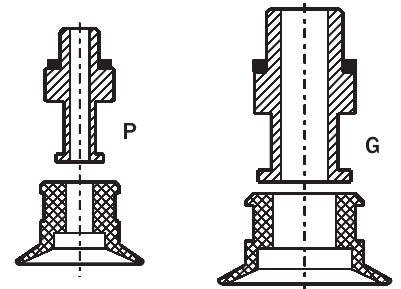

R Il raggio della più piccola sfera prendibile
Radius of the smallest grippable ball

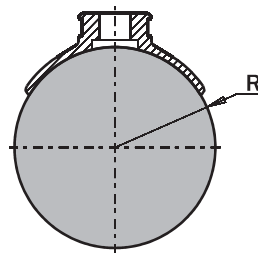

V Il volume interno
The inner volume

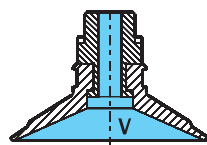

s Corsa verticale
Vertical stroke

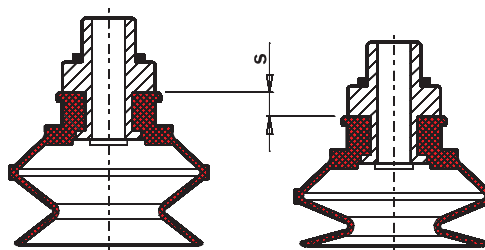

m Peso
Weight

F Capacità di aspirazione a -0.6bar
Suction force at -0.6bar